

## Stepper Motor Power Stage with ServiceBus

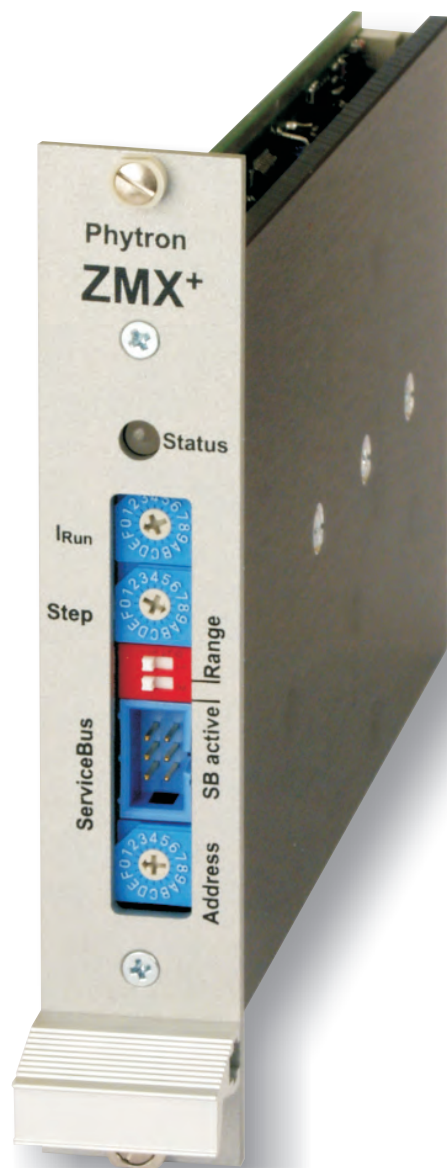

Any questions? Please contact us.

### Morskate Aandrijvingen BV

Oosterveldsingel 47A  
7558 PJ Hengelo (Ov)  
The Netherlands

NL

T +31 (0)74 - 760 11 11  
info@morskateaanrijvingen.nl  
www.morskateaanrijvingen.nl

DE

T +49 692 - 222 34 95  
info@morskateantriebstechnik.de  
www.morskateantriebstechnik.de

EN

T +31 (0)74 - 760 11 11  
info@morskatedrivetechnology.com  
www.morskatedrivetechnology.com

## Contents

1	ZMX <sup>+</sup> .....	4	7	Putting into Service .....	33
1.1	Overview .....	4	7.1	LED Display .....	33
1.2	Operating Mode.....	7	7.2	Rotary Switches.....	34
1.2.1	Rotary Switch Mode.....	7	7.3	DIP Switches .....	34
1.2.2	ServiceBus Mode .....	7	7.4	DIP Switch Setting .....	35
1.3	Directives and Standards.....	8	7.5	Rotary Switch Mode .....	36
1.4	Declaration of Incorporation.....	9	7.6	ServiceBus Mode.....	37
2	To Consider Before Installation .....	10	7.7	Checking the Installation .....	39
2.1	Qualified Personnel .....	10	8	Functions .....	40
2.2	Safety Instructions .....	10	8.1	Inputs.....	40
2.3	Ambient Conditions .....	12	8.1.1	CONTROL PULSES .....	42
3	Protective Measure Options .....	13	8.1.2	BOOST .....	43
4	Design Requirements .....	15	8.1.3	DEACTIVATION.....	43
4.1	Electromagnetic Compatibility (EMC) .	15	8.1.4	RESET .....	44
4.1.1	Remarks .....	15	8.1.5	DIRECTION .....	45
4.1.2	EMC Measures.....	16	8.1.6	STEP RESOLUTION .....	46
4.2	Shielding .....	18	8.2	Outputs .....	47
4.3	Insulation Overview .....	19	8.2.1	BASIC POSITION .....	47
4.4	Cables .....	20	8.2.2	ERROR.....	48
4.5	Calculation of the Supply Unit.....	21	9	ESD Protective Measures .....	49
4.6	Mains Supply Unit.....	22	10	Warranty and Trade Marks .....	50
5	Technical Data .....	23	10.1	Warranty .....	50
5.1	Mechanical Data.....	23	10.2	Trade Marks.....	50
5.2	Electrical Data .....	24	11	Technical Glossary .....	51
6	Installation .....	27	11.1	Boost .....	51
6.1	Mechanical Installation .....	27	11.2	Current Delay Time.....	52
6.2	Electrical Installation.....	28	11.3	Overdrive .....	53
6.2.1	Motor connection .....	28	12	Index.....	54
6.2.2	Wiring Schemes .....	30			
6.3	Connector.....	31			
6.3.1	ServiceBus Connector .....	31			
6.3.2	Connectors .....	31			

## 1 ZMX<sup>+</sup>

### 1.1 Overview

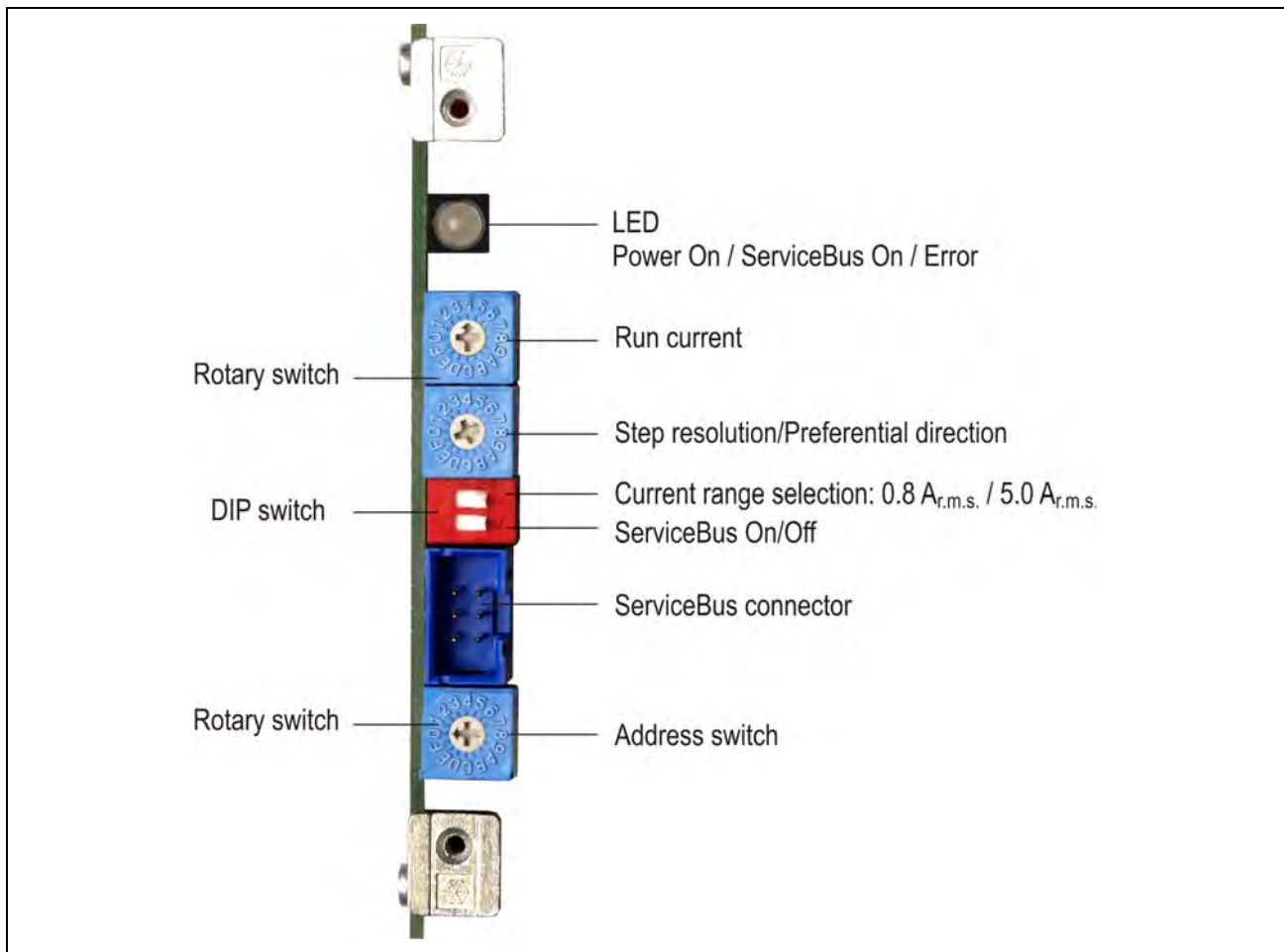

Fig. 1: Control components

#### Microstep Power Stage for Two-Phase Stepper Motors

The power stages type ZMX<sup>+</sup> are used for bipolar control of two-phase stepper motors with phytron's well-tried technology, now with enhanced 4 quadrant chopper type current control. The automatic phase current optimization ensures an accurate phase current regulation, even lower than 600 mA.

The operating parameters – run current, step resolution and preferential direction – can be set either by rotary switches (rotary switch mode) or by ServiceBus (ServiceBus mode).

The + of the power stage ZMX<sup>+</sup> stands for “operation with ServiceBus” by ServiceBus-Comm for Windows<sup>®</sup>. The configuration software is included in delivery for easy use of all setting options.

The ServiceBus enables configuration, programming and diagnostic via PC.

**ZMX+ versions**

<b>Electrical isolation</b>	with			without		
<b>Pin connector</b>	48 pin (F)	32 pin (D)		48 pin (F)	32 pin (D)	
<b>ServiceBus</b>	RS 485	RS 485	without	RS 485	RS 485	without
<b>Ident No.</b>	10016066	10016100	10015025	10016102	10015958	10015172
<b>Operating mode</b>	SBM or RSM		only RSM	SBM or RSM		only RSM

SBM= ServiceBus mode  
RSM= Rotary switch mode

**Electrical isolation**

The inputs and outputs are optically isolated from the ZMX+ power supply.

**VG Pin connector DIN 41612**

32 pin (D): Pin compatible with standard power stages on the market, ServiceBus connector at the front side.

48 pin (F): Additional ServiceBus connection at the SLS-ZMX+ power stage unit backplane.

**ServiceBus mode**

The ServiceBus offers the following possibilities:

- Power stage parameter programming:  
Run, stop and boost current, step resolution, preferential direction, current delay time, etc.
- Configuration by software via 4 wire or 2 wire RS 485 bus or CAN.
- Parameter memory to hold data safely in the power stage EPROM.
- Activate or deactivate the function Overdrive

The instruction set for power stage parameterization is listed in the ServiceBus manual.

The power stage can easily and quickly be programmed by ServiceBus-Comm<sup>®</sup> software. (See ServiceBus-Comm<sup>®</sup> manual)

# Manual ZMX<sup>+</sup>

---

## Rotary switch mode

The operating parameters – e. g. run current, step resolution, preferential direction – can be set by the rotary switches.

## Inputs

The logic of the inputs CONTROL PULSES, DIRECTION, BOOST, DEACTIVATION and RESET can be defined by the DIP switch on the board or by the ServiceBus.

## Outputs

Both outputs of the ZMX<sup>+</sup>, BASIC POSITION and ERROR, are open collector outputs.

## Easy to mount and EMC-compatible design

The ZMX<sup>+</sup> power stage is designed for mounting in 19"/3U racks.

All wiring is connected to a 32 pin connector (type D) or a 48 pin connector (type F) according to DIN 41612 depending on the version.

## Extent of supply

### Included in delivery:

- ZMX<sup>+</sup> manual
- ZMX<sup>+</sup> with ServiceBus:      ServiceBus-Comm manual  
   ServiceBus manual  
   Phytron CD with the ServiceBus-Comm software

### Supplementary parts are available:

- Front panel with handle (#10010085)
- ServiceBus cable
- CAN bus terminating plug
- USB-RS 485 converter as stick (#10012295)

## 1.2 Operating Mode

---

The ZMX<sup>+</sup> can be served by 2 operating modes:

### 1.2.1 Rotary Switch Mode

---

All operating mode parameters are set by the DIP and rotary switches at the front side or on the board.

### 1.2.2 ServiceBus Mode

---

The **SB active** DIP switch activates the ServiceBus mode when “ON” and all operating parameters can only be set by ServiceBus.

**RS bus:** The parameters for the ZMX<sup>+</sup> operation are set via RS 485 4 wire mode (full duplex).

**CAN bus:** The ZMX<sup>+</sup> parameterization is set by a **Controller Area Network (CAN)** in the 2 wire mode. Up to 16 power stages can be connected to one CAN bus.

All settings are made on a PC by phytron’s ServiceBus-Comm<sup>®</sup> software.

The **Address** rotary switch address of the device.

**Important:** Each address must only be used once!

## 1.3 Directives and Standards

<b>CE Mark</b>	With the declaration of conformity and the CE Mark on the product the manufacturer certifies that the product complies with the requirements of the relevant EC directives. The unit, described here, can be used anywhere in the world.
<b>EC Machine Directive</b>	The drive system, described here, isn't a machine in the sense of the EC machine directive (2006/42/EC), but a component of a machine for installation. They have no functional moving parts. But they can be part of a machine or equipment. The conformity of the complete system in accordance with the machine guideline is to be certified by the manufacturer with the CE marking.
<b>EC EMC Directive</b>	The EC Directives on electromagnetic compatibility (89/336/EEC) applies to products, which can cause electromagnetic interference or whose operation can be impaired by such interference. The power stage's compliance with the EMC Directive cannot be assessed until it has been installed into a machine or installation. The instructions provided in "Installation" must be complied with to guarantee that the ZMX <sup>+</sup> is EMC compliant when fitted in the machine or installation and before use of the device is permitted.
<b>Standards for safe operation</b>	EN 60204-1: 1998-11: Electrical equipment of machines, degree of pollution 2 must be observed EN 60529: IP Degree of protection
<b>Standards for observing the EMC limit values</b>	EN 61000-3-2: EMC EN 61000-6-1,3,4: Emission standard EN 61000-6-2:2005: EMC Immunity for industrial environments
<b>Standards for measuring methods of observing EMC limit values</b>	EN 55011 class B: Noise field and voltage measuring EN 61000-4-2...6,11 Emission standard test

## 1.4 Declaration of Incorporation



### Declaration of Incorporation according to EC directive 2006/42/EC on machinery (Annex II B) for partly completed machinery

**Name and address of the manufacturer:**

Phytron-Elektronik GmbH,  
Industriestr. 12  
82194 Gröbenzell

**Representative in EU, authorized to compile the relevant technical documentation:**

Rainer Gareis  
Phytron-Elektronik GmbH,  
Industriestr. 12  
82194 Gröbenzell

**Description of the partly completed machinery:**

**Product denomination:** Stepper Motor Power Stage  
**Model/Type:** ZMX, ZMX+

From serial number 1001xxxxx

**We declare that the product complies with the following essential requirements of the Machinery Directive 2006/42/EC:**

1.1.2.; 1.1.5.; 1.3.4.; 1.5.1.; 1.5.2.; 1.5.4.; 1.5.5.; 1.5.6.; 1.5.16.; 1.6.3.; 1.6.4.; 1.7.2.; 1.7.3.; 1.7.4.

**In addition the partly completed machinery is in conformity with the following EC Directives:**

EC Directives 2004/108/EC relating to electromagnetic compatibility.

**We declare that the relevant technical documentation is compiled in accordance with part B of Annex VII.**

We commit to transmit, in response to a reasoned request by the market surveillance authorities, relevant documents on the partly completed machinery.

**Important note! The partly completed machinery must not be put into service until the final machinery into which it is to be incorporated has been declared in conformity with the provisions of Directive 2006/42/EC on Machinery, where appropriate, and until the EC Declaration of Conformity according to Annex II A is issued.**

Gröbenzell, 2010-02-24

  
Johannes Schmid  
Technical Director

AP QS-0670-4  
CE 7001 Rev. 1

Phytron-Elektronik GmbH  
Industriestr. 12 - 82194 Gröbenzell  
Postfach 1255 - 82180 Gröbenzell  
T +49-8142-503-0 F +49-8142-503-190  
E info@phytron.de W www.phytron.de

Geschäftsführung Birgit Hartmann  
Reg.-Gericht München - HRB 44 474  
USt-Ident-Nr. DE 128 242 222  
Steuernummer 117-135-10027

Genossenschaftsbank - Kto 96610 - BLZ 70169464  
IBAN DE 6770 1694 6400 0009 6610 - BIC GENODEF1M07  
Sparkasse Fürstenfeldbruck - Kto 1801265 - BLZ 70053070  
Oberbank München - Kto 1041021021 - BLZ 70120700  
Volksbank Fürstenfeldbruck - Kto 712531 - BLZ 70163370  
Postbank München - Kto 0286001800 - BLZ 70010080



## 2 To Consider Before Installation

---



Read this manual very carefully before installing and operating the ZMX<sup>+</sup>.  
Observe the safety instructions in the following chapter!

### 2.1 Qualified Personnel

---

Design, installation and operation of systems using the ZMX<sup>+</sup> may only be performed by qualified and trained personnel.

These persons should be able to recognize and handle risks emerging from electrical, mechanical or electronic system parts.

The qualified personnel must know the content of this manual and be able to understand all documents belonging to the product. Safety instructions are to be planned.

The trained personnel must know all valid standards, regulations and rules for the accident prevention, which are necessary for working with the product.



#### **WARNING**

Without proper training and qualifications damages to devices and injury might result!

### 2.2 Safety Instructions

---



The ZMX<sup>+</sup> is designed for operating in a 19" rack.  
An installation is only allowed, if the requirement of the EC Machine Directive and EMC are conformed with. See chap. 1.3 and 1.4.



This product is used as a part of a complete system, therefore risk evaluations concerning the concrete application must be made before using the product.  
Safety measures have to be taken according to the results and be verified.

Personnel safety must be ensured by the concept of this complete system (e.g. machine concept).



#### **WARNING**

**Injury or damage by overvoltage!**

Operate the ZMX<sup>+</sup> only in accordance with the protective measures in chap. 3.

**ATTENTION**



**Risk of damage by false motor current setting!**

The ZMX<sup>+</sup> power stage is set to a defined current on delivery!  
The motor current must be set to the designated value before installation (see data of the motor).

**DANGER**



**Danger of electric arcing!**

Always switch off the supply voltage before connecting or disconnecting any wires or connectors at the power stage.  
Do not unplug the connector while powered!

**DANGER**

**Danger of electric shock!**



Up to 3 minutes after turning off the supply voltage, dangerous voltages may still exist at the connectors or the board.

Set the power stage (e.g. motor current) **only** disconnected from the mains with a fitting adjusting tool.



**DANGER**

**Danger of touch voltages!**

The transformer **must** be constructed with reinforced or double insulation to avoid dangerous touch voltages (50 V<sub>AC</sub> and 120 V<sub>DC</sub>) in case of isolation error in the transformer.

**WARNING**



**Danger of injury if touching the surface!**

The surface of the ZMX<sup>+</sup> reaches temperatures more than 105 °C during operation.



Energizing the inputs DEACTIVATION or RESET is not safe in the case of an emergency stop.

The voltage supply has to be interrupted for safe isolation of the drive.

## 2.3 Ambient Conditions

---

<b>Installation</b>	Mounting in 19" rack
<b>Permissible ambient temperature</b>	operation: 4 to 40 °C storage: -25 to +55 °C transport: -25 to +85 °C
<b>Permissible heat sink temperature</b>	max. 90 °C
<b>Relative humidity</b>	The relative humidity is certified while in operation as follows:  According to EN 50178, class 3K3  5% to 85%, no condensation permissible
<b>Degree of pollution</b>	2
<b>Device protection</b>	Degree of protection according to DIN EN 60529:1991 IP20 at operation in a 19" rack
<b>Wiring</b>	Use at least 75 °C resistant copper cable.

### 3 Protective Measure Options

The power stage must be operated by the protective measure PELV acc. to VDE 0100. Board and motor housing have to be grounded and/or connected to 0 V.

Various options are possible to achieve the protective measure PELV:

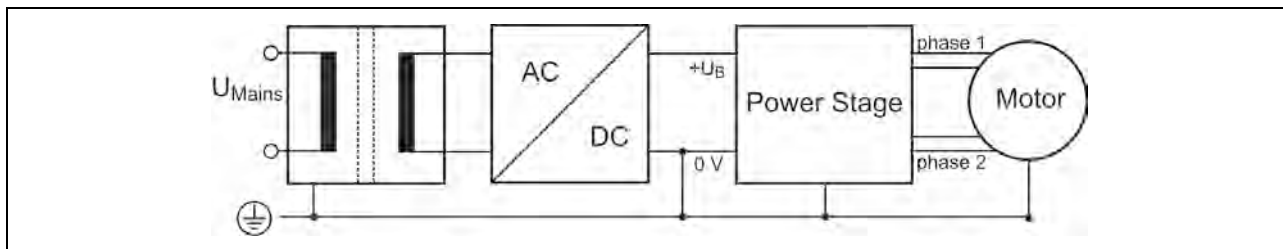

Fig. 2: PELV – Grounding: total

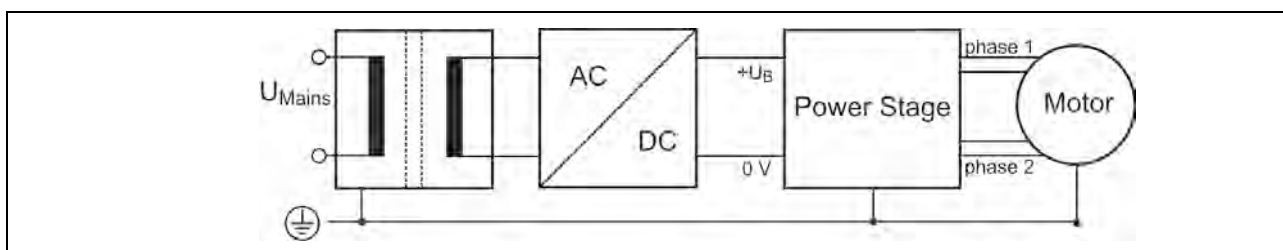

Fig. 3: PELV – Grounding: Power Stage and Motor. The secondary winding of the transformer (SELV supply) must not be grounded because the equipment is grounded.

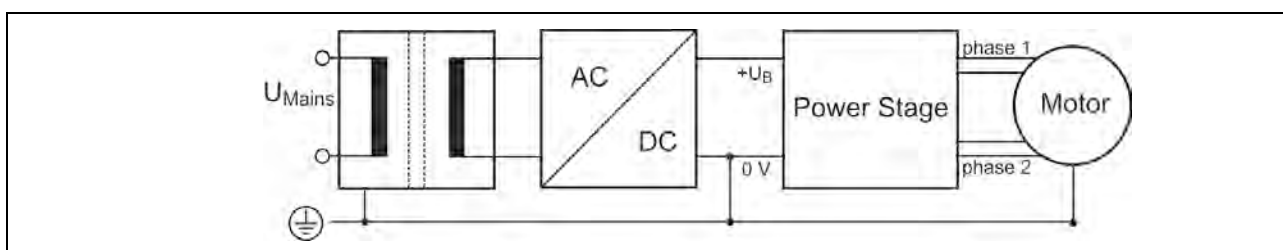

Fig. 4: PELV – Grounding: 0 V and Motor

If there is no PE clamp on the motor, the 0 V wire **must** be grounded to complete the protective measure PELV (Fig. 5 and Fig.6):

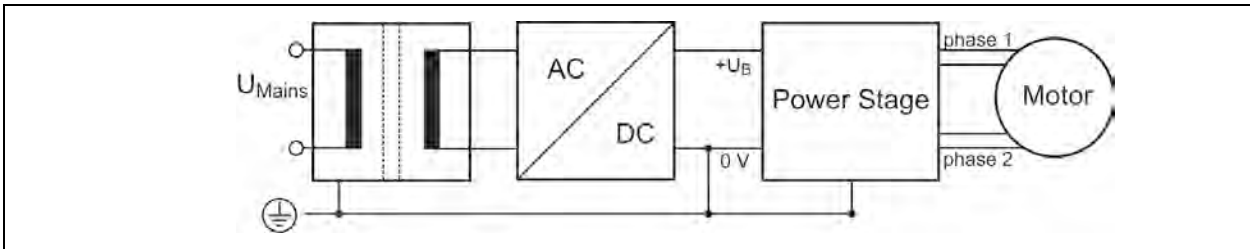

Fig. 5: PELV – Grounding: 0 V and Power Stage

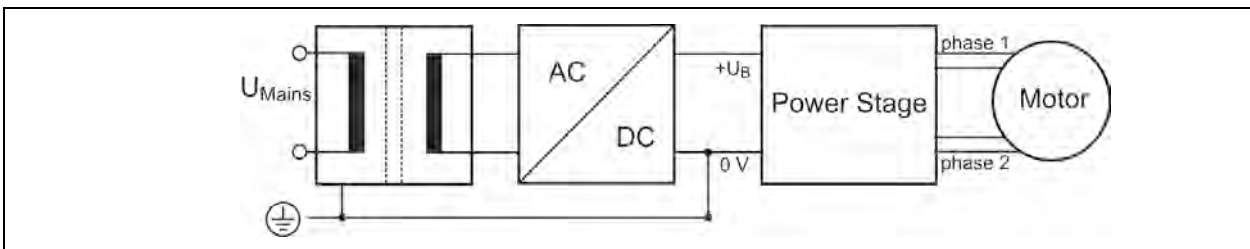

Fig. 6: PELV – Grounding: 0 V



Protective measure PELV for application of the  $+U_B$  should not exceed  $70 V_{DC}$  or  $50 V_{AC}$  in a dry environment (environmental conditions 3 acc. to IEC 61201).

The supply transformer must be constructed with reinforced or double isolation between supply and secondary winding (acc. to EN 61558).

Only use motors which are checked to EN 60034-1 ( $500 V_{AC}/1$  minute).

## 4 Design Requirements

### 4.1 Electromagnetic Compatibility (EMC)

#### 4.1.1 Remarks

---



#### **DANGER**

#### **Risk of injury by interference of signals and devices!**

Perturbed signals can cause equipment to react unexpectedly.

- Connect the power stage to the EMC requirements.
- In electrically noisy environments ensure the correct execution of the EMC measures. Disregarding these precautions can cause death, serious injuries or material damages.

A condition for the adherence to the indicated limit values is a EMC-compatible structure. Depending upon application better results can be obtained by the following measures:

- Power choke connected downstream.  
You receive data of current harmonic on request.
- External line filter connected downstream, in particular to conform to the limits when using long motor cables.
- Special EMC compatible assembling, e. g. in a closed switching cabinet with 15 dB damping of the emitted interference.



#### **ATTENTION**

#### **Risk of failure!**

Step errors can occur in case of sudden supply voltage drops. An absolute monitoring of the step accuracy is ensured with a superior measuring system using e. g. an encoder.

## 4.1.2 EMC Measures

	EMC Measures	Effect
<b>19" rack mounting</b>	Use the front panel with the mounting screws, the front panel ensures large contact to the 19" rack.	Good conductivity due to planar contacts.
	Fit switching devices such as contactors, relays or solenoids with interference or spark suppressors (e. g. diodes, varistors, RC elements).	Reduction of mutual interference.
	Mount power and control components separately.	Reduction of mutual interference.
<b>Cabling</b>	Keep cables as short as possible. No "safety loops".	Avoidance of capacitive and inductive interference
	Connect the shielding of all shielded cables to the 19" rack by the cable clamps to a large area on the rear panel of the rack.	Reduction of EMC emissions.
	Lay the cables spatially separated from each other: <ul style="list-style-type: none"> <li>• signal and power cables</li> <li>• power and master cables</li> <li>• line filter input and output cables</li> </ul>	Avoidance of mutual interference.
	Ground a large surface area of the shieldings of digital signal cables.	Stray interference on control cables, reduction of emissions.
<b>Power supply</b>	Protective circuit to mitigate over voltage or lightning strikes.	Protection of damage by over voltage.

**Preset for EMC: Motor cable**

The motor cable is a source of interference and must be carefully laid.

Use the cables recommended by phytron. They are tested for EMC safety and are suitable for movement.

The motor and the encoder cable of the driving system must be connected to a large surface area of the output of the control cabinet and the motor with a low resistance.

- Connect the motor cables without interruption (don't use switching elements) from the motor to the device. If a cable must be interrupted, use shielding connections and metal housings to avoid interferences.
- Lay the motor cable at a distance of at least 20 cm from the signal cables. If they are laid closer together, motor cable and signal wiring must be shielded and grounded.
- Use potential equalization cables with suitable cross section when the cables are long.

**Potential equalization cables**

Connect the shielding on all sides for protection from interference.

The difference of potential can cause incorrect currents on the shielding and must be avoided by potential equalization cables.



## 4.2 Shielding

To avoid interference affecting the wires and instruments installed close to the drive system, we recommend the use of shielded cables.

The plug-in board, where the ZMX<sup>+</sup> is installed, should be connected to the ground by a central earthing tab.

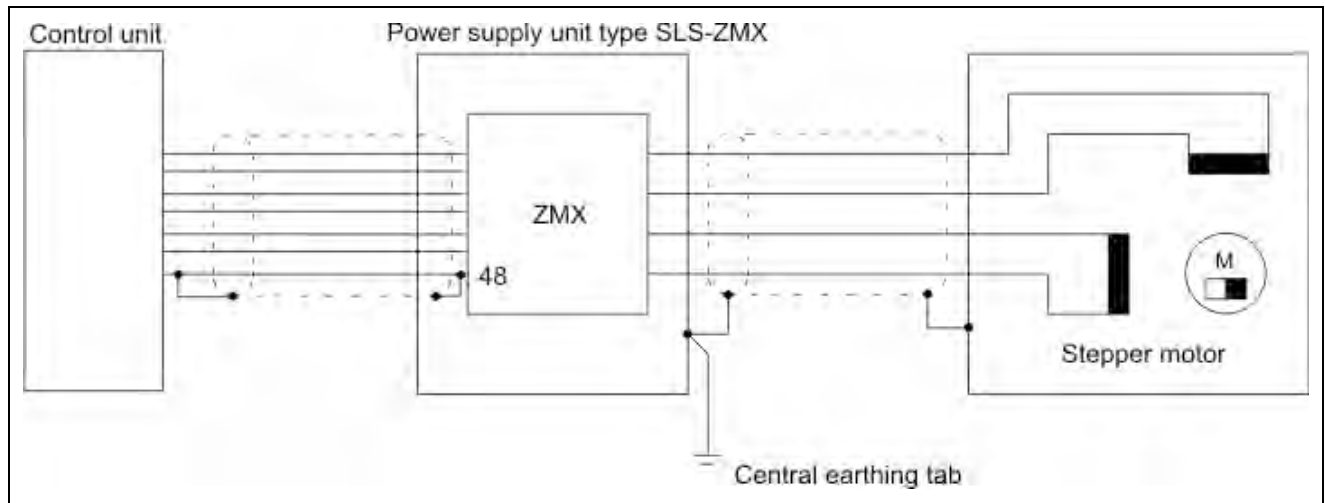

Fig. 7: Motor cable shielding

### 4.3 Insulation Overview

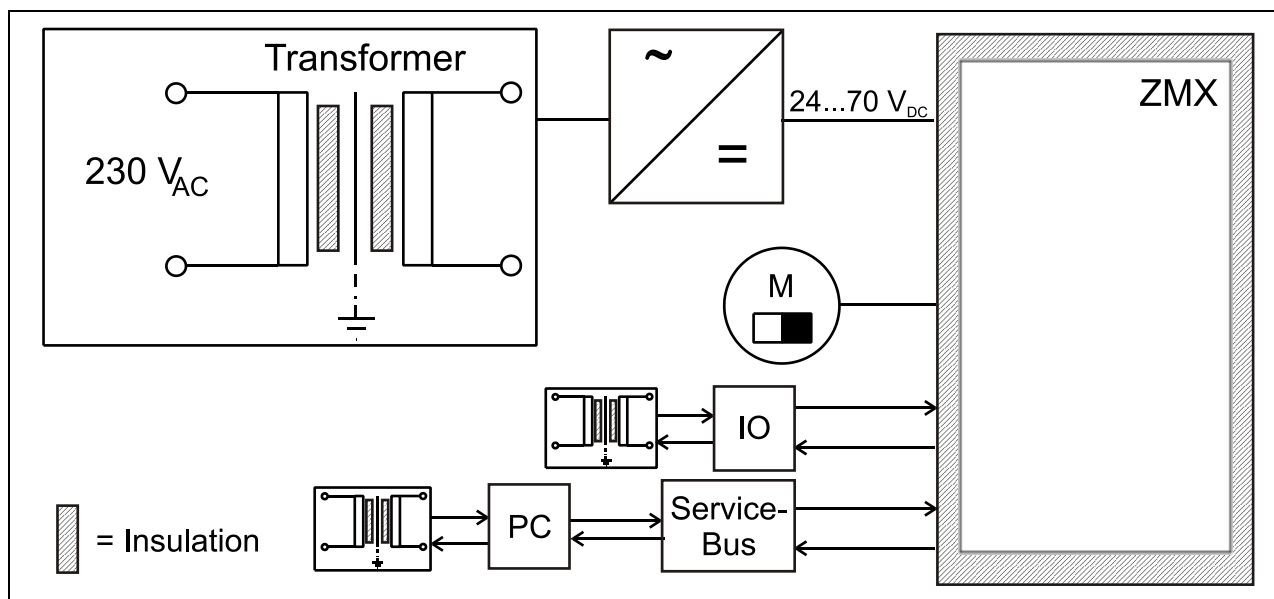

Fig. 8: ZMX<sup>+</sup> Insulation



#### WARNING

#### Injury or damage by overvoltage!

The power stage must be operated with protective measure PELV.  
The transformer should be constructed with reinforced or double isolation.

The isolation of the ZMX<sup>+</sup> fulfils the requirements of a basic isolation for non-mains circuits for voltages up to 141 V acc. to EN 50178.

The device has been designed for degree of pollution 2 acc. to EN 50178.

The IO signals on the connectors are safely electrically isolated by optocoupler.

The signals RS 485 on the ServiceBus connectors are electrically isolated from the motor voltage by a separate DC/DC converter (withstand voltage 800 V<sub>DC</sub>).



Devices connected to ZMX<sup>+</sup> for control or communication should have reinforced or double isolation acc. to EN 50178.

## 4.4 Cables

### Overview:

	max. cable length [m]	min. cross section [mm <sup>2</sup> ]	shielded, grounded on all sides	twisted pair
<b>Motor cable</b>	The length depends on the cable resistance: $R_{\text{cable}} < 0.2 \times R_{\text{phase}}$	Dependent on the maximum current of the motor and the motor cable length is suitable:		
	25	0.1 per 1 Ampere motor current	X	X
	50	0.2 per 1 Ampere motor current	X	X
<b>Signal interface</b>	100	0.14	X	
<b>ServiceBus cable</b>	2	–		

### Motor cable:

Motor cable length	Min. cable cross section for phase currents	
	up to 3 A <sub>r.m.s.</sub>	from 3 to 6.5 A <sub>r.m.s.</sub>
up to 10 m	1.0 mm <sup>2</sup>	1.0 mm <sup>2</sup>
10 m to 25 m	1.0 mm <sup>2</sup>	1.5 mm <sup>2</sup>
25 m to 50 m	1.5 mm <sup>2</sup>	2.5 mm <sup>2</sup>

## 4.5 Calculation of the Supply Unit

Consider the following instructions for calculation of the supply unit:

1. If the **cables from the supply unit to the ZMX<sup>+</sup>** are longer than 50 cm, a capacitor with about 47  $\mu\text{F}/100\text{ V}$  must be connected in parallel to the connector as far as possible.

The capacitor must be suitable for switching applications and have a low ESR (Equivalent Series Resistance).

2. **Transformer**, load capacitor:

Transformer:  $U = 50\text{ V}_{\text{AC}}$   $I = 5\text{ A}$

Load capacitor:  $C1 = 4,700\ \mu\text{F}$

The power indications for the transformer and the load capacitor are "worst-case" values, i. e.: computed for a maximum motor power, permanent boost function activation and a 100 % load factor. The actual values must be determined for the real operating conditions.

For the load capacitor, a value of 1,000  $\mu\text{F}$  per Amp of motor current can be used. The thermal limit values of the transformer must never be exceeded.

The internal resistance of the supply module must be good enough to avoid a DC voltage drop of more than 15 % below the peak value, at maximum load.



**The transformer must be constructed with reinforced or double isolation.**

The secondary winding of the transformer must not be grounded (SELV supply).

3. **Rectifier:**

The rectifier must be able to dissipate losses up to 2 Watts per Amp.

If necessary, mount a heat sink.

## 4.6 Mains Supply Unit

The ZMX<sup>+</sup> power stage can be supplied by means of an unregulated filtered DC voltage from 24 to 70 V<sub>DC</sub>.

Operating voltage range: 24 to 70 V<sub>DC</sub>

Nominal voltage: 70 V<sub>DC</sub>

The voltage must not drop under 22 V and rise over 80 V, not even for a short time (> 1 msec). If the external voltage falls below 22 V or rises over 80 V, the ZMX<sup>+</sup> detects an error.

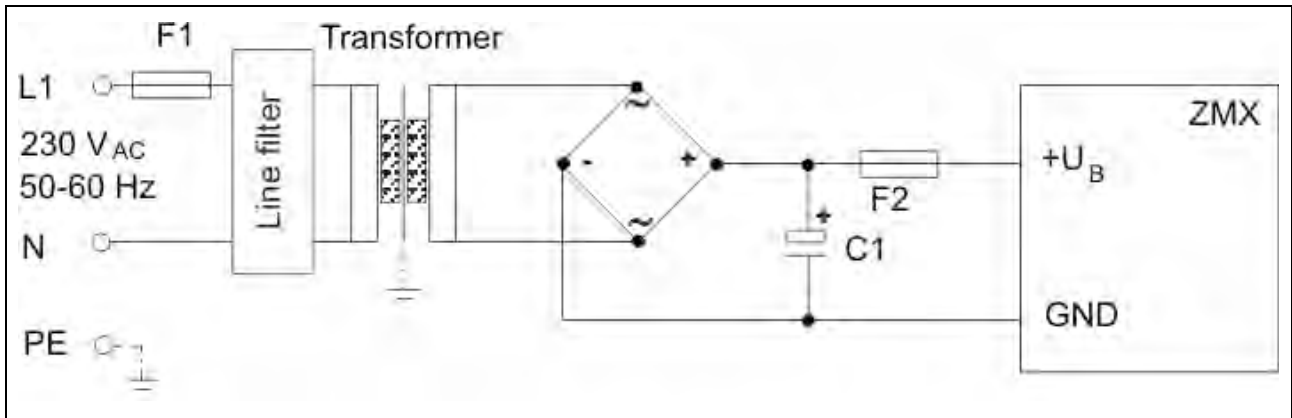

Fig. 9: Mains supply unit

**For calculation and connection of the supply unit, the following instructions must be followed:**

-  **The transformer must be constructed with reinforced or double isolation.**

- **i** The calculation of the F2 fuse depends on the preset phase current and the motor load:

Recommended values:

Phase current	Fuse
≤ 1 A	T2A
2 A	T4A
3 A	T6A
4 A	T8A
5 A	T10A
≥ 6 A	T12A

- For the load capacitor, a value of 1,000 μF per Amp of motor current should be calculated.
- Use shielded cables for DC supply.

## 5 Technical Data

### 5.1 Mechanical Data

<b>Type</b>	Standard Euro Board format 96 x 146 mm Pluggable to the Phoenix adaptor SKBI 64/F-48 (Ident-No. 2264093) Front plane 3 U / 5 HP
<b>Weight with front plate</b>	about 450 g
<b>Mounting</b>	Mounting in 19"/3 U rack All connectors are led through to a 32 pin connector (type D) or 48 pin connector (type F) according to DIN 41612 depending on the version.

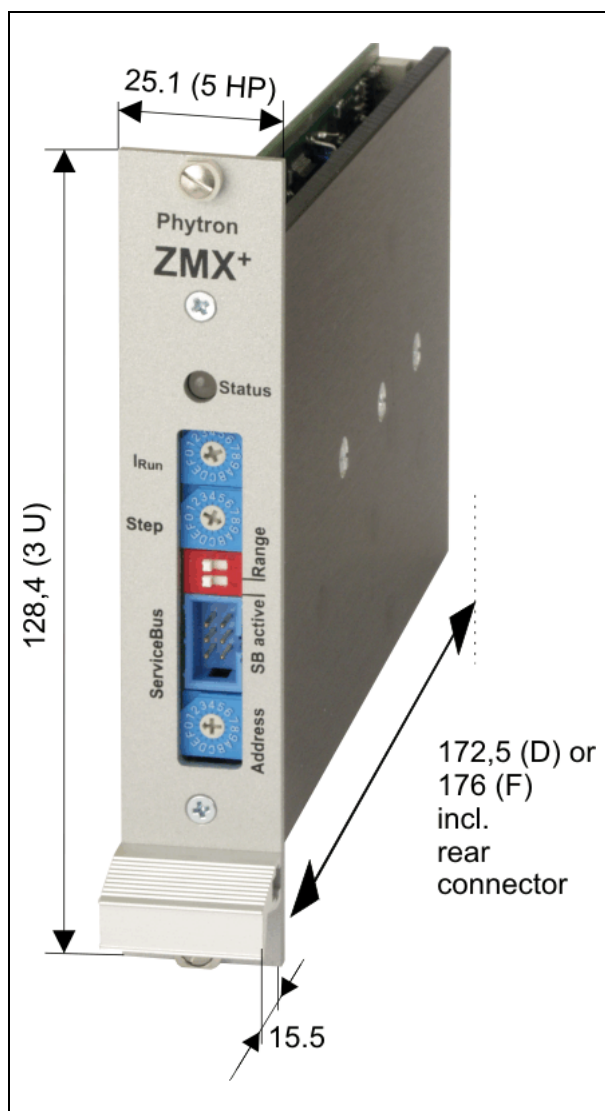

Fig. 10: Dimensions

## 5.2 Electrical Data

<b>Supply voltage</b>	Unregulated filtered DC voltage from 24 to 70 V <sub>DC</sub> Nominal voltage 70 V <sub>DC</sub> Reinforced or double isolation between mains and secondary circuit	
<b>Stepper motor</b>	Two phase stepper motors with 4, 6 or 8 lead wiring scheme Winding resistance between 0.1 and 10 ohm Winding inductance 0.5 to 10 mH per phase	
<b>Step resolution</b>  Rotary switch mode  ServiceBus mode	The step resolution can be set by the rotary switch: 1/1, 1/2, 1/4, 1/5, 1/8, 1/10, 1/20 of a full step.	
	The step resolution is programmable: 1/1, 1/2, 1/2.5, 1/4, 1/5, 1/8, 1/10, 1/16, 1/20, 1/32, 1/64, 1/128, 1/256, 1/512 of a full step.	
<b>Phase currents</b>  Rotary switch mode     without Boost: with Boost:	Run current can be individually set by the rotary switch. Stop current is 50 % of the run current. With the <b>Range</b> rotary switch ( <b>fine</b> and <b>wide</b> ) the run current between 2 ranges can be switched.	
	<b>Rotary switch position</b>	
	ON = fine	OFF = wide
	0.1 to 0.8 A <sub>r.m.s.</sub> 0.15 to 1.1 A <sub>r.m.s.</sub> 0.2 to 1.5 A <sub>Peak</sub>	0.7 to 5.0 A <sub>r.m.s.</sub> 0.9 to 6.5 A <sub>r.m.s.</sub> 1.3 to 9 A <sub>Peak</sub>
ServiceBus mode	Run current is programmable from 0 to 6.5 A <sub>r.m.s.</sub> in 0.1 A steps.	

<b>Inputs</b>	The logic of the inputs can be defined by rotary switch (on the board) or by ServiceBus.																																												
CONTROL PULSES	Maximum step frequency: 750 kHz Pulse width > 1 $\mu$ s to ensure control pulses reliability																																												
DIRECTION	The motor direction is inverted by input activation.																																												
BOOST	In rotary switch mode: The run current is increased by about 30 % on input activation.  Boost current is programmable in the ServiceBus mode.																																												
DEACTIVATION	Both motor phases are switched off when the input is activated.																																												
RESET	The power stage is reset to the defined initial state. A signal basic position is generated for each reset.																																												
STEP RESOLUTION	<p>If this input is activated and the step resolution is preset by the rotary switch, the step resolution is positioned one step below.</p> <p>Examples for a 200-step motor:</p> <table border="1" data-bbox="528 1032 1442 1464"> <thead> <tr> <th>Rotary switch setting</th> <th>FS</th> <th>HS</th> <th>1/2.5</th> <th>1/4</th> <th>1/5</th> <th>1/8</th> <th>1/10</th> <th>1/20</th> </tr> </thead> <tbody> <tr> <td>Steps</td> <td>200</td> <td>400</td> <td>500</td> <td>800</td> <td>1000</td> <td>1600</td> <td>2000</td> <td>4000</td> </tr> <tr> <td>Input not active or not wired</td> <td>FS</td> <td>HS</td> <td>1/2.5</td> <td>1/4</td> <td>1/5</td> <td>1/8</td> <td>1/10</td> <td>1/20</td> </tr> <tr> <td>Input active</td> <td>FS</td> <td>FS</td> <td>HS</td> <td>1/2.5</td> <td>1/4</td> <td>1/5</td> <td>1/8</td> <td>1/10</td> </tr> </tbody> </table> <p><b>The input may not be changed during operation!</b></p>									Rotary switch setting	FS	HS	1/2.5	1/4	1/5	1/8	1/10	1/20	Steps	200	400	500	800	1000	1600	2000	4000	Input not active or not wired	FS	HS	1/2.5	1/4	1/5	1/8	1/10	1/20	Input active	FS	FS	HS	1/2.5	1/4	1/5	1/8	1/10
Rotary switch setting	FS	HS	1/2.5	1/4	1/5	1/8	1/10	1/20																																					
Steps	200	400	500	800	1000	1600	2000	4000																																					
Input not active or not wired	FS	HS	1/2.5	1/4	1/5	1/8	1/10	1/20																																					
Input active	FS	FS	HS	1/2.5	1/4	1/5	1/8	1/10																																					



<b>Outputs</b>	Electrical isolated by optocoupler, open collector type $I_{\max} = 20 \text{ mA}$ , $U_{\max} = 45 \text{ V}$ , $U_{\text{CE sat}} \text{ at } 20 \text{ mA} < 0.6 \text{ V}$
<b>BASIC POSITION</b>	Zero crossing of the integrated ring counter is indicated; active LOW
Full step	every 4th control pulse
Half step	every 8th control pulse
1/2,5 step	every 10th control pulse
1/4 step	every 16th control pulse
1/5 step	every 20th control pulse
1/10 step	every 40th control pulse
1/20 step	every 80th control pulse
<b>ERROR</b>	Supply voltage $< 22 \text{ V}_{\text{DC}}$ Over temperature ( $T > 90 \text{ }^{\circ}\text{C}$ ): If the permissible heat sink temperature is exceeded, the power stage is deactivated. The LED goes to red. Over current, short circuit $> 30 \text{ A}$ for a short time An error signal deactivates the power stage.
<b>ServiceBus connector</b>	6 pin connector, type Tyco Electronics 2-1761605-1/609-0607
<b>Connector</b>	32 pin VG connector acc. to DIN 41612, type D 48 pin VG connector acc. to DIN 41612, type F

## 6 Installation

### 6.1 Mechanical Installation

---



#### **DANGER**

#### **Danger of electric shock by foreign particles or damage!**

Loose conductive parts inside the device or damages can cause parasitic voltage.

Don't use faulty equipment.



#### **WARNING**

#### **Danger of damage of system parts by hot surfaces!**

The heat sink on the device can heat up to more than 105 °C depending on the operation.

Avoid touching the hot heat sink.

#### **Ventilation:**

Consider the following remarks before installation the power stage into a 19" rack:

- Sufficient cooling of the device by a fan. Avoid heat accumulation.
- Don't install the device close to heat sources and on combustible materials.
- The heated air flow from other devices and components doesn't result in excessive heating of the cooling air.
- The device switches off by operation over the thermal limit because of over temperature.



#### **Control cabinet:**

The control cabinet must be dimensioned in such a way that all devices and components inside can be firmly mounted and wired in the line with EMC requirements.

The ventilation of the control cabinet must dissipate the heated air flow of all mounted devices and components inside.

## 6.2 Electrical Installation

---

	The ZMX <sup>+</sup> power stage is designed for operation in a 19" rack!
	<b>Risk of failure!</b> The connection wires to the connector must be connected with <u>all</u> specified pins. Example: + U <sub>B</sub> is connected to the pins 8a, 8c, 10a and 10c (type D) or pins 8z, 8d, 10z and 10d (type F).

### 6.2.1 Motor connection

---

The following chapter describes how to wire different types of two phase stepper motors. ZMX<sup>+</sup> stepper motor power stages may be connected to stepper motors with 0.1 to 9 A<sub>Peak</sub> phase current.

The stepper motor winding resistance should be less than 10 ohm for full power.

The winding inductance of one phase should not be lower than 0.5 mH.

Stepper motors with 8 leads can be connected with the windings wired in parallel (1) or series (2).

For 6-lead stepper motors, wiring scheme (3) with series windings is recommended.

If wiring scheme (3) cannot be used because of the motor construction, the motor may be operated with only two of the four windings energized according to wiring scheme (5).



#### **Damage of the power stage!**

5-lead stepper motors must **not** be connected to the ZMX<sup>+</sup>.  
**Both 5-lead stepper motor and ZMX<sup>+</sup> might be damaged.**

**Motor time constant  $\tau$ :**

$\tau = \frac{L}{R}$  applies to the electric motor time constant  $\tau$ .

The total inductance  $L_{total}$  is equal to the winding inductance in a parallel circuit, because of interlinked inductances.

$L_{total} = 4 \times L$  applies to a series circuit.

The result is an equal motor time constant  $\tau$  for a serial and a parallel circuit:

<b>Circuit</b>	<b>series</b>	<b>parallel</b>
<b>Resistance <math>R_{total}</math></b>	<b>2 x R</b>	<b><math>\frac{R}{2}</math></b>
<b>Inductance <math>L_{total}</math></b>	<b>4 x L</b>	<b>L</b>
<b>Motor time constant <math>\tau</math></b>	<b><math>\tau_{series} = \frac{4 \times L}{2 \times R} = \frac{2 \times L}{R}</math></b>	<b><math>\tau_{parallel} = \frac{L}{R/2} = \frac{2 \times L}{R}</math></b>

6.2.2 Wiring Schemes

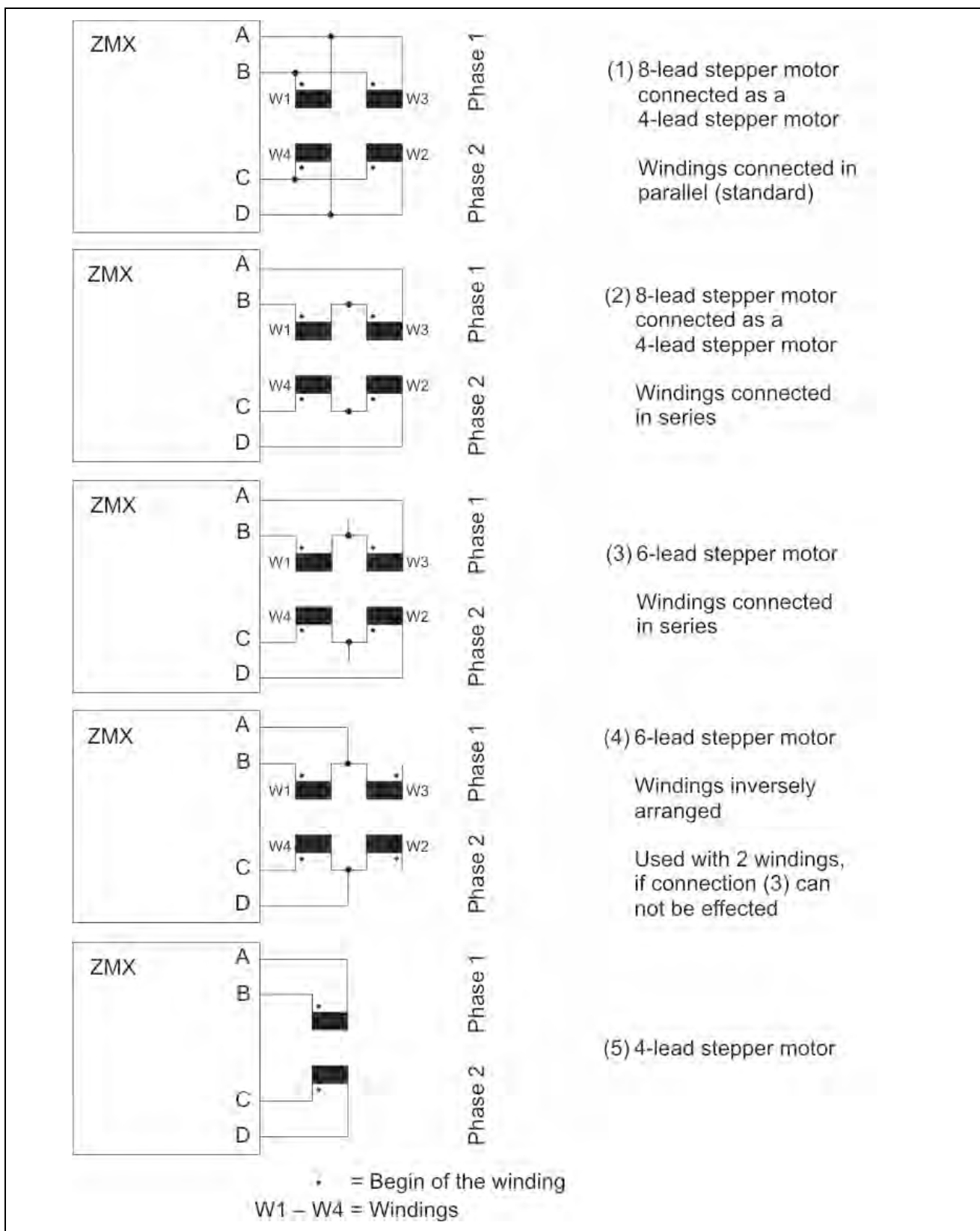

Fig. 11: Connection diagrams for 4-, 6- and 8- wire stepper motors

## 6.3 Connector

### 6.3.1 ServiceBus Connector

The ZMX<sup>+</sup> power stage is connected to the 6 pin **ServiceBus** connector in the ServiceBus mode by suitable cables.

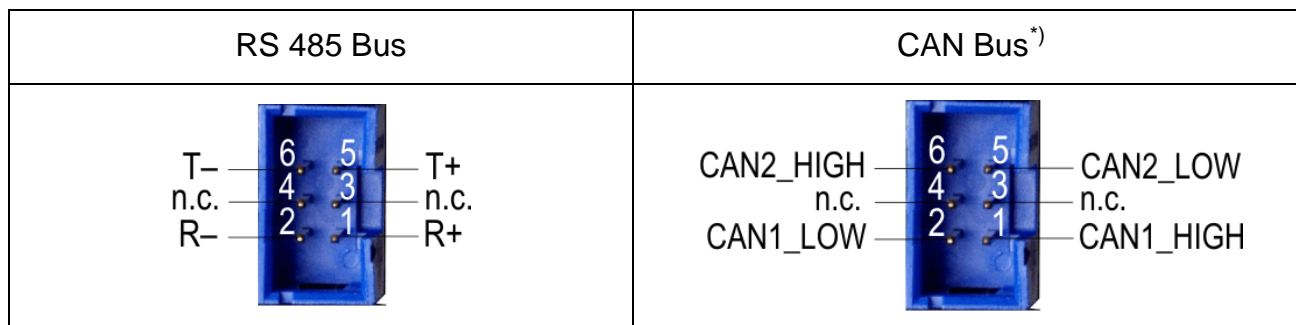

Fig. 12: ServiceBus connector type Tyco Electronics 2-1761605-1/609-0607

### 6.3.2 Connectors

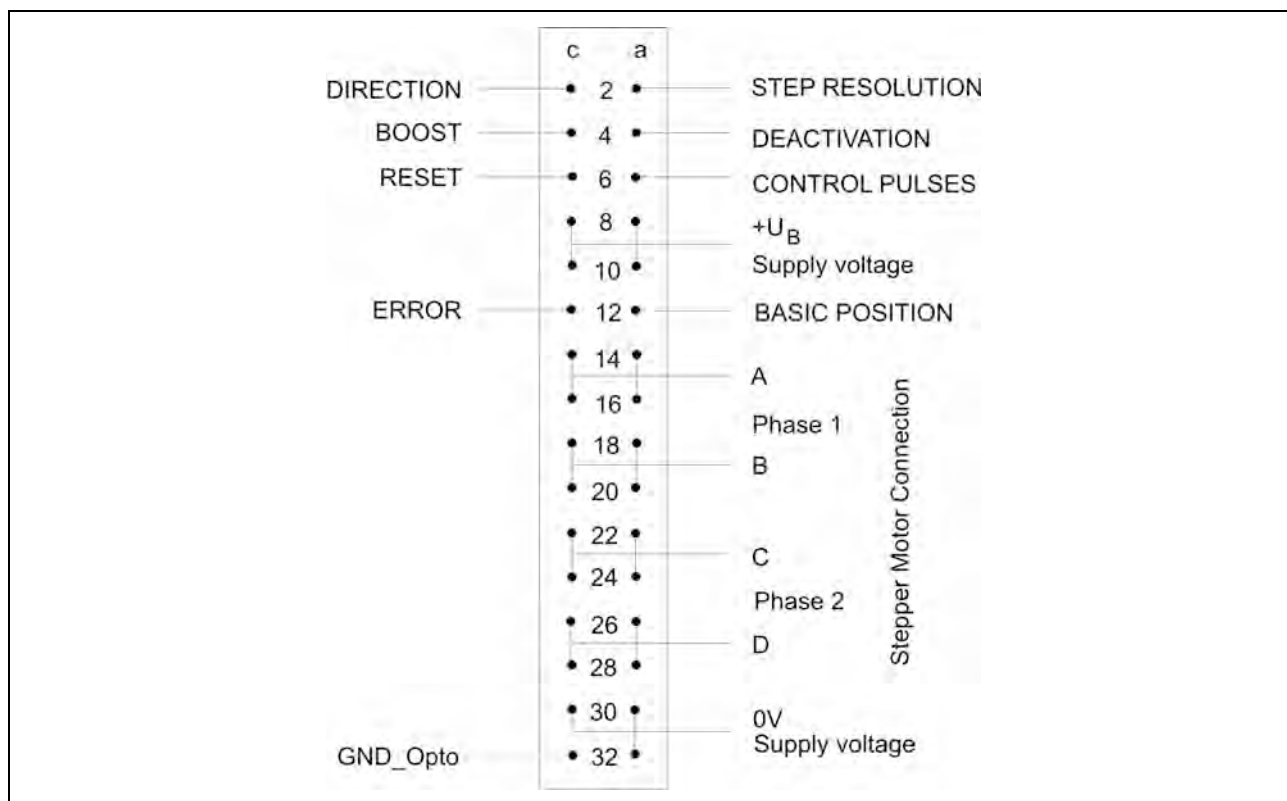

Fig. 13: 32 pin VG connector, type D acc. to DIN 41612

<sup>\*)</sup> CAN2 is not used in the actual SW.

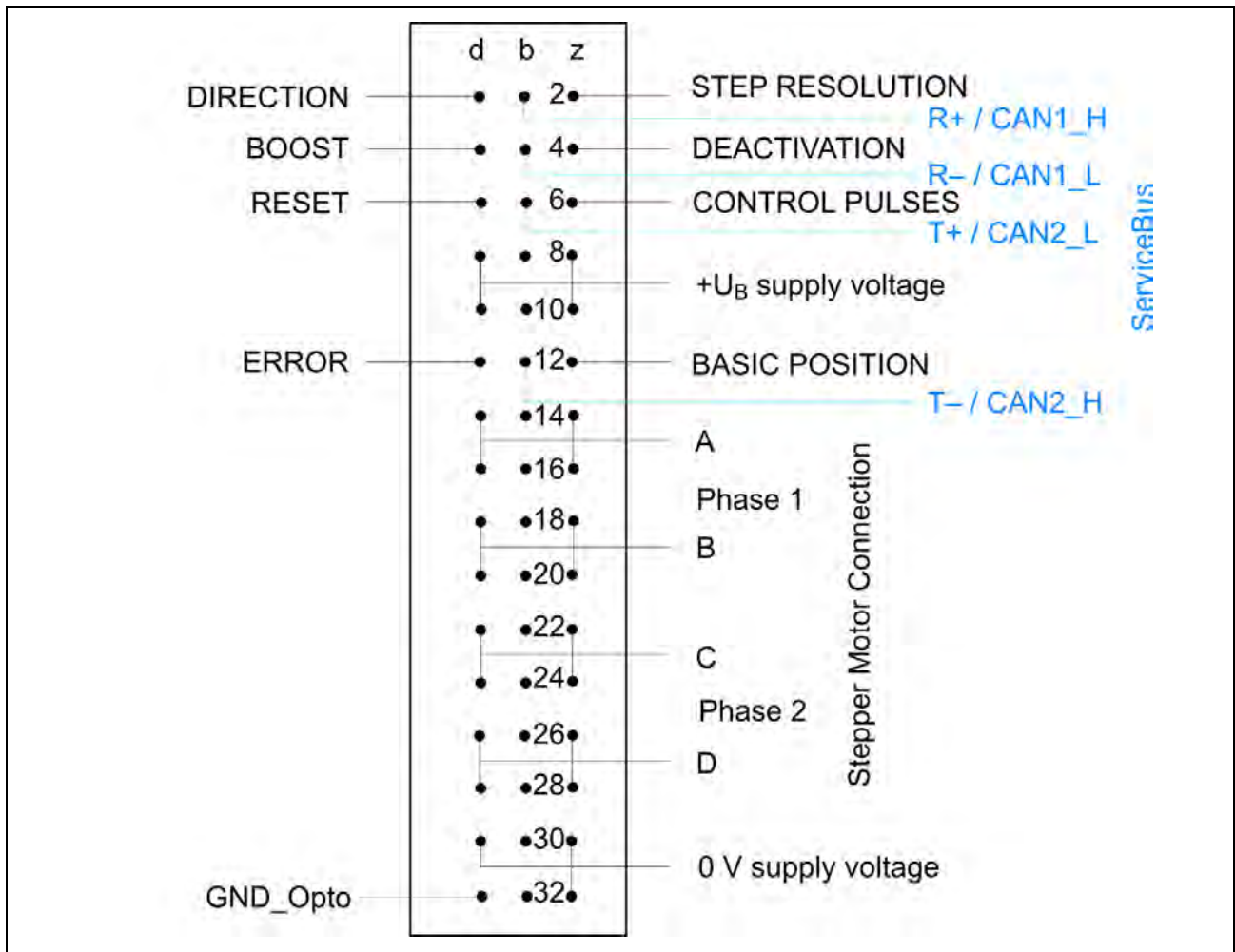

Fig. 14: 48 pin VG connector, type F acc.to DIN 41612







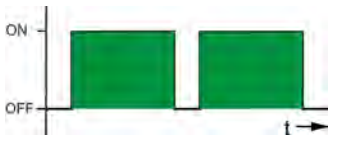

Differentiation of the GND pin assignment:

ZMX <sup>+</sup> version	32 pin VG connector	48 pin VG connector
With electrical isolation	Pin 30a,30c,32a: 0 V Pin 32c: GND_Opto	Pin 30d,30z, 32z: 0 V Pin 32d: GND_Opto
Without electrical isolation	Pin 30a,30c,32a,32c: 0 V	Pin 30d,30z, 32d,32z: 0 V

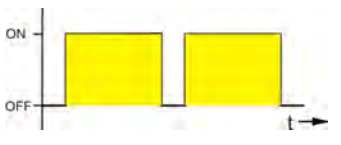
## 7 Putting into Service

### 7.1 LED Display

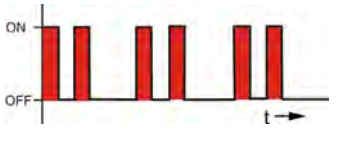
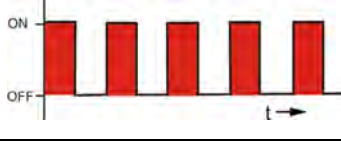
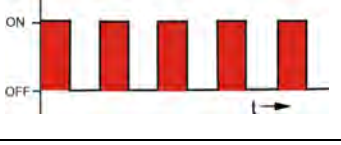
The LED indicates the status of the power stage by color changes and blinking:

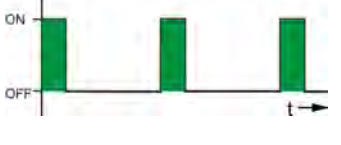
	in Rotary switch mode	in ServiceBus mode	
<b>LED</b>	lights up permanently	blinks	
<b>Ready</b>			The power stage is ready.
<b>Busy</b>			Control pulses are received by the controller.
<b>Fault</b>	A monitoring circuit responded:		
			Over current: > 30 A
			Under voltage: < 22 V
			Over temperature: >90 °C
<b>Reset/ Disabled</b>			Input RESET is active. Input DEACTIVATION is active.



## 7.2 Rotary Switches

---

The rotary switches on the front side are used to:

- set the run current  $I_{Run}$
- set the step resolution and the preferential direction by **Step** rotary switch
- address the power stage **Address** rotary switch.



Fig. 15: 16-step rotary switch: Setting 0...F

## 7.3 DIP Switches

---

The current range and the ServiceBus can be selected by the DIP switches at the front side.

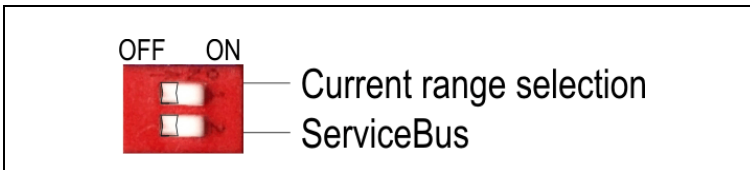

Fig. 16: DIP switches at the front side

The DIP switches on the board input logic, overdrive and output ERROR are defined.

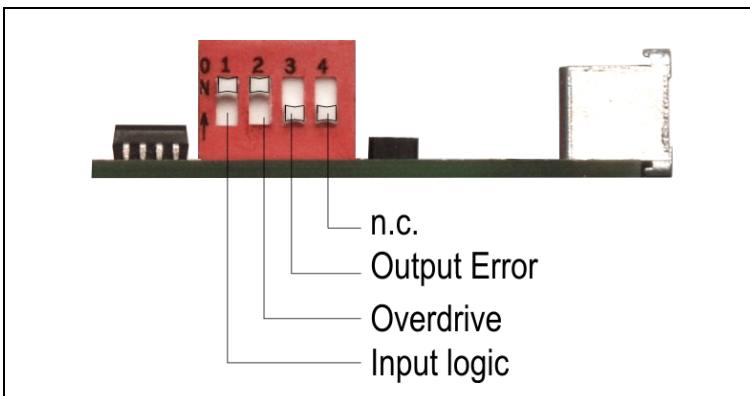
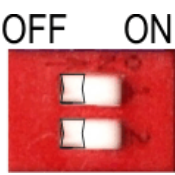

Fig. 17: DIP switches on the board

## 7.4 DIP Switch Setting

The **Range** DIP switch on the front side is used for changing the current range. **SB active** activates the ServiceBus mode.

	Function	Position OFF	Position ON
	1 Current range selection [A <sub>r.m.s.</sub> ]	Wide: 0.7 to 5.0	Fine: 0.1 to 0.8
	2 ServiceBus	off	on



### Risk of power stage failure!

The ServiceBus mode is activated exclusively by setting the **SB active** DIP switch to “ON”.

The following functions can be adjusted by the DIP switches on the board:

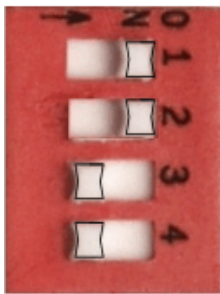
	Function	Position OFF	Position ON
	1 Input logic	positive	negative
	2 Overdrive	deactivated	activated
	3 Output ERROR	NCC	NOC
	4 n.c.	–	–

The function Overdrive is described in chap. 11.3.

## 7.5 Rotary Switch Mode

The run current is adjusted by the  $I_{Run}$  rotary switch, the step resolution and preferential direction by the **Step** rotary switch.

For fine run current setting you can change between two ranges (**wide** or **fine**). Boost increases the run current by 30 %.

Rotary switches					
Switch setting	Run current [A <sub>eff</sub> ] $I_{Run}$		Step resolution/ Preferential direction Step	ZMX <sup>+</sup> versions	
	Switch setting			without electrical isolation	with electrical isolation
	fine	wide			
0	0.12	0.7	Full step	+	–
1	0.17	1.0	Half step	+	–
2	0.21	1.3	1/2,5	+	–
3	0.26	1.6	1/4	+	–
4	0.31	1.8	1/5	+	–
5	0.36	2.1	1/8	+	–
6	0.40	2.4	1/10	+	–
7	0.45	2.7	1/20	+	–
8	0.50	3.0	Full step	–	+
9	0.55	3.3	Half step	–	+
A	0.60	3.6	1/2,5	–	+
B	0.64	3.9	1/4	–	+
C	0.69	4.1	1/5	–	+
D	0.74	4.4	1/8	–	+
E	0.79	4.7	1/10	–	+
F	0.83	5.0	1/20	–	+
Factory settings					

**Important:** The current values of this table have been verified with the phytron stepper motor ZSH 87.2/200.8.4. Deviation is possible for other motors.

## 7.6 ServiceBus Mode

The operation parameters can be set by the serial RS 485 bus connection (ServiceBus) in the ZMX<sup>+</sup>. If more than one ZMX<sup>+</sup> is operated (max.16), the RS 485 bus (4 wire operation) or CAN bus is best choice.

In order to activate the ServiceBus, the **ServiceBus active** DIP switch must be set to "ON".

The **Address** rotary switch sets the address of the power stage in the ServiceBus.

**Important:** Each address (0...F) must only be used once!

Read ServiceBus manual for more information about the ServiceBus instruction code.

The connection of the ZMX<sup>+</sup> power stage acc. to **RS 485** (4 wire operation):

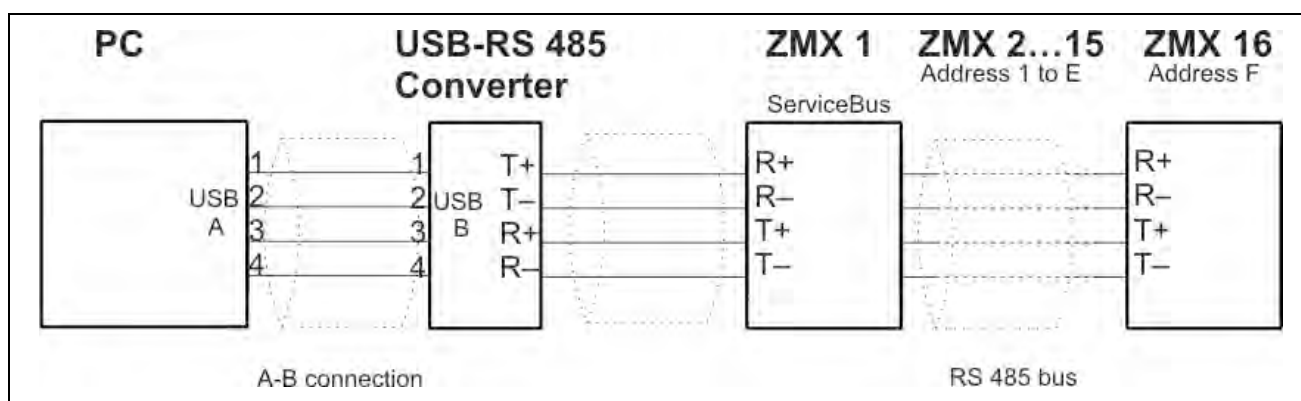

Fig. 18: Connection PC -> ZMX<sup>+</sup> via USB/RS 485 converter

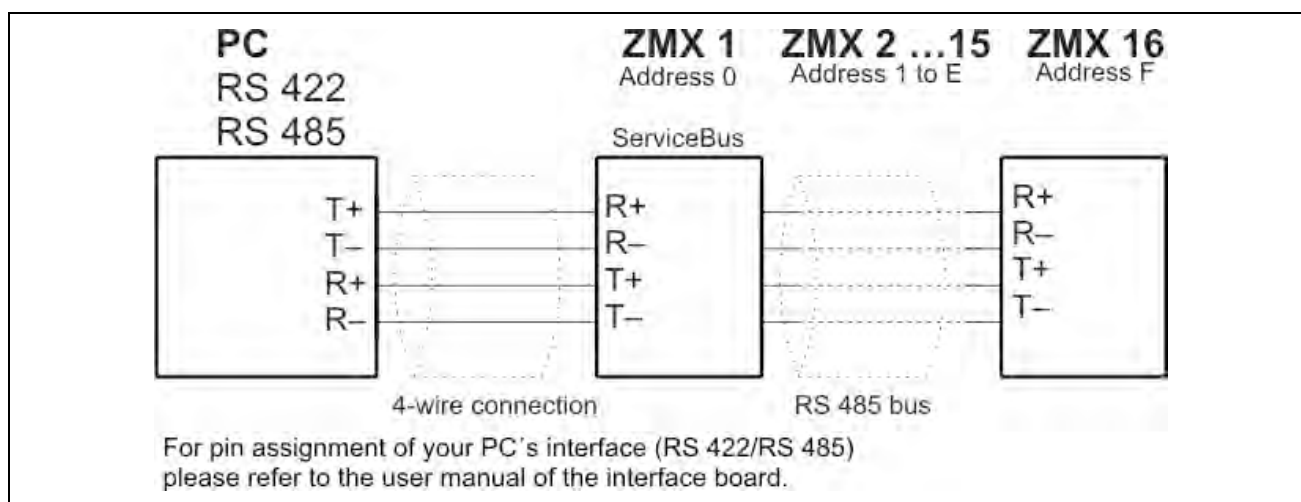

Fig. 19: Connection PC -> ZMX<sup>+</sup> with RS 422/RS 485 interface

# Manual ZMX<sup>+</sup>

The ZMX<sup>+</sup> power stage connection acc. to **CAN**:

The ZMX<sup>+</sup> power stage is designed as a slave device for connection to a superior controller or PC. The parameterization is made via CAN bus to the controller. The bus has to be connected by a physical bus termination at each end. The controller terminates on one side, on the other side a termination resistor must be connected.

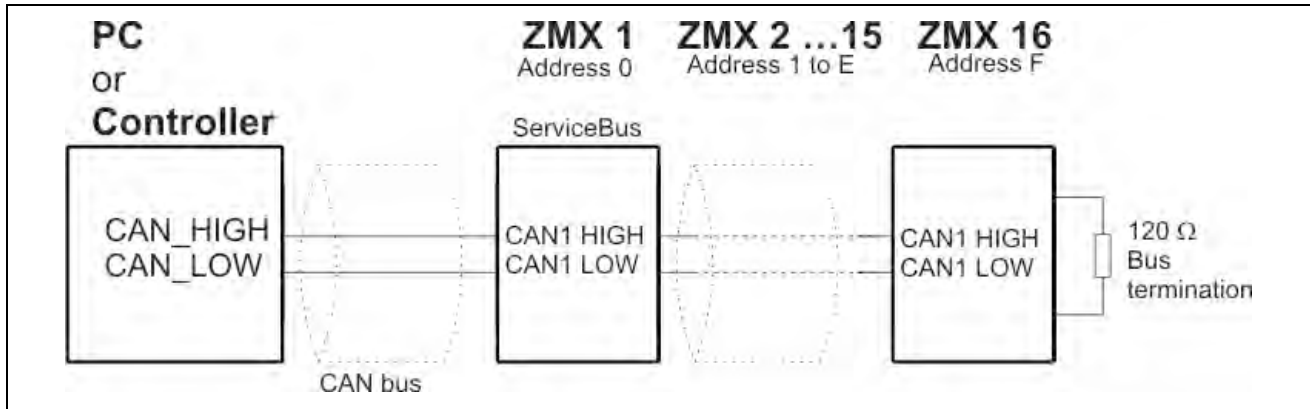
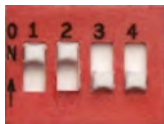

Fig. 20: Connection PC/Controller -> ZMX<sup>+</sup> with CAN bus interface

## 7.7 Checking the Installation

The following steps check the correct installation and hidden transport damages of the ZMX<sup>+</sup> power stage:

1. Connect the ZMX<sup>+</sup> acc. to "Protective Measure" in chap. 3.
2. Select the designated current range – fine or wide – with the **Range** DIP switch.
3. The DIP switches (on the side) are set as follows:



4. For setting the rotary switches see the table in chapter 7.5 "Rotary Switch Mode":
  - **I<sub>Run</sub>** rotary switch: Setting of the designated run current
  - **Step** rotary switch: Selecting the step resolution and preferential direction
5. **Motor, supply voltage and signal lines** are connected via connector by the mating connector or in the 19" rack.
6. Connect the input signals to the input CONTROL PULSES.
7. **Switch on the power supply** of the ZMX<sup>+</sup>.  
As soon as the ZMX<sup>+</sup> is supplied with voltage and no error occurs the LED shines green.
8. **Testing the signals:**  
Check the holding torque of the motor by trying to rotate the motor shaft by hand. An active motor can't either be rotated or only with difficulty.
9. Apply the control pulses and check whether the motor is moving.
10. Invert the polarity of the direction signal by the **Step** rotary switch and set the steps for the motor. The direction of rotation must change.
11. If there is no reaction of the power stage, the input logic has to be inverted by the DIP switch (on the side).

## 8 Functions

### 8.1 Inputs

The logic of the inputs CONTROL PULSES, DIRECTION, BOOST, DEACTIVATION and RESET can be defined by the DIP switches on the board or by ServiceBus.

Permissible input voltage range: 0 to 30 V<sub>DC</sub>

Input logic examples by input wiring:

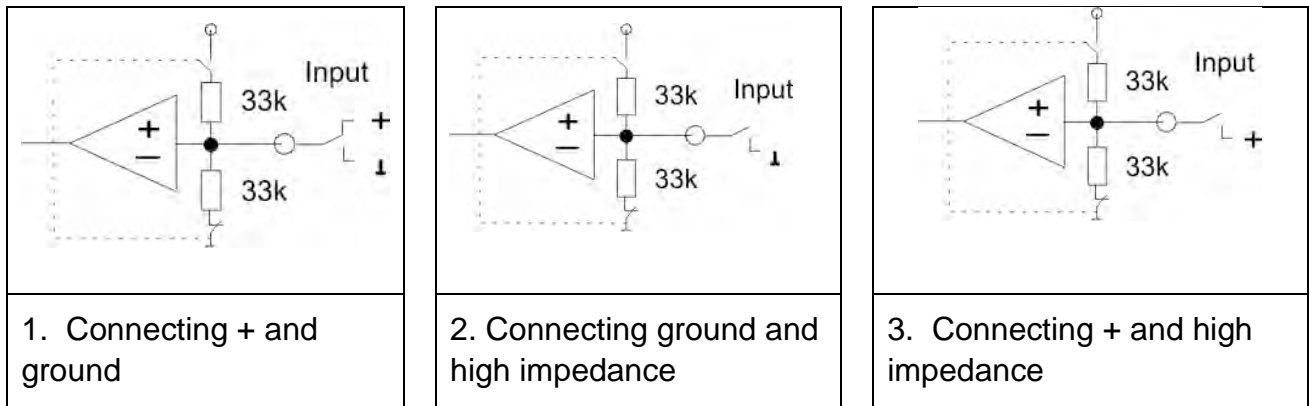

,Input logic' DIP switch: Changing of the logic functions:

positively and negatively	only negatively (ON Position)	only positively (OFF Position)
---------------------------	-------------------------------	--------------------------------



#### Input functions!

Example 1 only ensures the inverting of the input logic!

The limit switching value for the inputs CONTROL PULSES, DIRECTION, BOOST, DEACTIVATION is

Input logic	Limit switching value
positive	> 4 V
negative	< 2.5 V

**ZMX<sup>+</sup> version with “electrical isolation”:**

The controller inputs CONTROL PULSES, BOOST, DIRECTION, DEACTIVATION, STEP RESOLUTION and RESET are isolated by optocoupler from the power supply (+U<sub>B</sub>) of the ZMX<sup>+</sup>. An optimal transient suppression is reached between controller and main circuit.

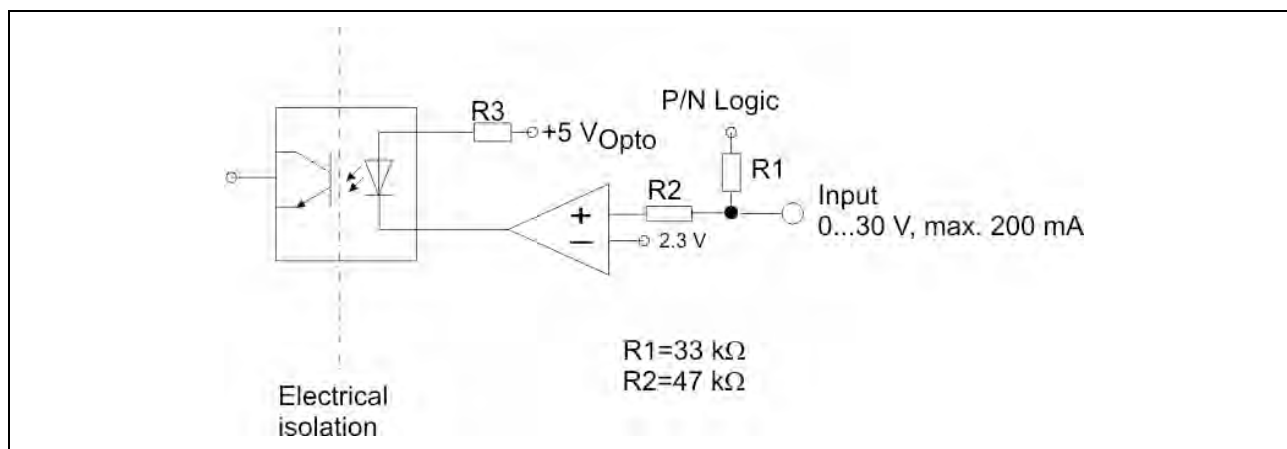

Fig. 21: Input circuit “electrical isolation”

**ZMX<sup>+</sup> version without “electrical isolation”:**

The inputs are wired without optocoupler and GND is connected to GND\_Opto by hardware.

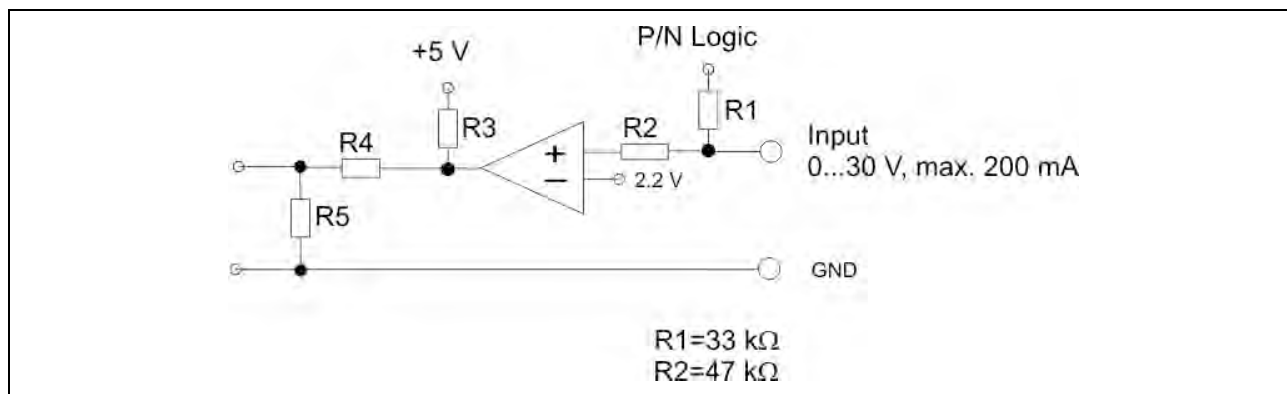

Fig. 22: Input circuit “without electrical isolation”



## 8.1.1 CONTROL PULSES

Maximum step frequency: 750 kHz

Pulse width > 1 μs to ensure control pulses reliability

The clock pulse of at least 1 μs causes one motor step. The step is done with the first clock pulse.

ZMX <sup>+</sup> version	DIP switch 1 input logic	High	Low
without electrical isolation	ON	–	The run current is set with the <b>falling</b> edge and the step is done.
	OFF	The run current is set with the <b>rising</b> edge and the step is done.	–
with electrical isolation	ON	The run current is set with the <b>rising</b> edge and the step is done.	–
	OFF	–	The run current is set with the <b>falling</b> edge and the step is done.

The control pulses sequence must not suddenly start or stop, if the control pulse frequency is higher than the start/stop frequency of the motor. Misposition of the motor would be the result.

The start/stop frequency is defined as that frequency, from which a stepper motor can start from standstill without losing a step. Typical values for the start/stop frequency are 200 to 2000 Hz. The exact value depends on the load torque and the load inertia on the motor shaft.

If the motor is to be operated above the start/stop frequency range, the indexer has to generate frequency ramps to accelerate and decelerate the motor.

### Current delay time:

After the last control pulse the stop current is activated after a time. The time after the last control pulse until the change to the stop current is called current delay time.

In rotary switch mode the current delay time is set to 40 ms default value.

In ServiceBus mode the current delay time is programmed as parameter and saved in the ZMX<sup>+</sup> (see chap. Technical Glossary).

**i** If the control pulses voltage decreases under 5 V, the maximum control pulse frequency (750 kHz) can be reduced. The higher this voltage so much higher the possible step frequency.

## 8.1.2 BOOST

If the input is activated, the ZMX<sup>+</sup> changes to boost current. The power stage increases the run and stop current by 30 % in the rotary switch mode. As long as the BOOST input is energized, the run and stop current will always be 30% higher.

The boost current can be programmed by the user in ServiceBus mode (from 0 to 6.3 A<sub>r.m.s.</sub>).

Thus, a higher torque can be reached during the acceleration and deceleration time of the motor by changing to boost current.

Also see chapter Technical Glossary.

## 8.1.3 DEACTIVATION

If the input is energized, the motor current is disconnected.

This input is useful, for instance, for service operations to switch the power stage off, without having to disconnect it physically from the mains. Now it is possible to rotate the motor slowly by hand.



### Function of the DEACTIVATION input!

The DEACTIVATION input must not be used to replace emergency stop circuit requirements!

The DEACTIVATION input may only be energized during standstill of the motor axis.

The function deactivation may also be used to avoid the inevitable noise emissions of the power stage, e. g. if you have to perform sensitive electrical measurements in the environment of the device.

DIP switch 1 Input logic	High	Low
ON	Power stage deactivated	No deactivation
OFF	No deactivation	Power stage deactivated

## 8.1.4 RESET

If the input is activated, all error signals and the ring counter are reset. The ring counter is set to basic position. Both motor phases are energized by the same current value in basic position independent of the step resolution.

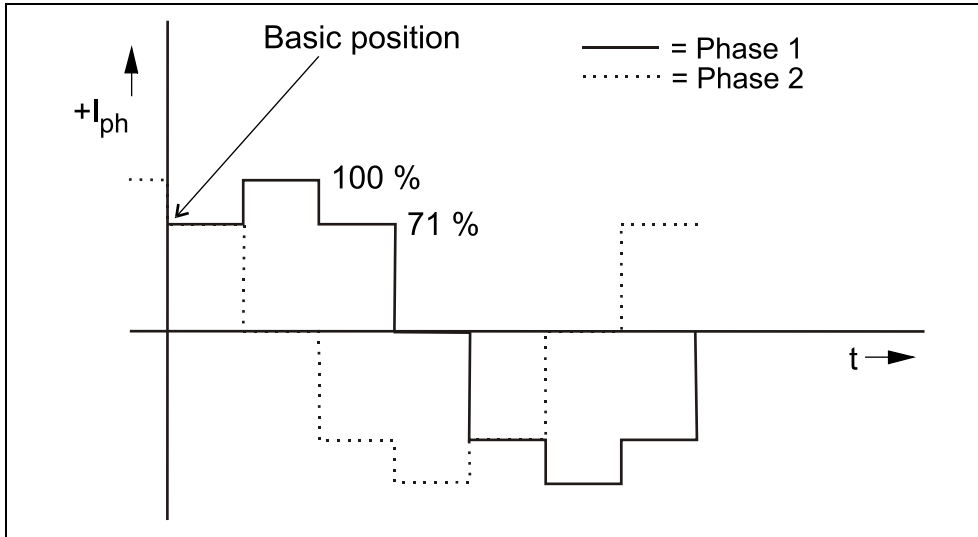

Fig. 23: Motor phases in basic position (half step)

After activation of the reset signal, the power stage will enable the ready signal approximately 500 ms later.

DIP switch 1 Input logic	High	Low
ON	Reset activated	no Reset
OFF	no Reset	Reset activated

---

## 8.1.5 DIRECTION

---

This signal changes the motor direction which is defined by the motor wiring and the manufacturer's specifications.

### WARNING

#### Changing of the input signal!



A change of the signal is only allowed when the stepper motor is at standstill or driven with a speed within the start/stop range.

The signal may not change 1  $\mu$ s before and up to 4  $\mu$ s after the clock pulse. Changing the direction at higher speed causes step loss or standstill of the motor.

In the rotary switch mode the preferential direction can be changed by the **Step** rotary switch (see table in chap. 7.5).

In the ServiceBus mode the preferential direction can be programmed. (see ServiceBus manual).

## 8.1.6 STEP RESOLUTION

---

Activating or deactivating this input switches from one step resolution to the other.

If the step resolution is fixed by rotary switch, the activation of the input STEP RESOLUTION positiones the step resolution one stage **below**.

Example for a 200 step motor:

Setting by rotary switch	FS	HS	1/2.5	1/4	1/5	1/8	1/10	1/20
Steps	200	400	500	800	1000	1600	2000	4000
Input STEP RESOLUTION positive or not wired	FS	HS	1/2.5	1/4	1/5	1/8	1/10	1/20
Input STEP RESOLUTION negative	FS	FS	HS	1/2.5	1/4	1/5	1/8	1/10



### WARNING

**Changing the step resolution during operation might damage the power stage!**

The input STEP RESOLUTION must only be changed before the first clock pulse has arrived after power on or resetting the power stage.

**Observe the limit switching value of this input!** See chap. 8.1 !

In the ServiceBus mode the step resolution can be programmed.  
(see ServiceBus manual).

## 8.2 Outputs

Both outputs of the ZMX<sup>+</sup>, BASIC POSITION and ERROR, are open collector outputs.

ZMX<sup>+</sup> version “electrical isolation”:

The outputs are isolated by optocoupler from the ZMX<sup>+</sup> power supply.

**Remark:** Pin 32d and/or Pin 32c serve as GND\_Opto.

ZMX<sup>+</sup> version **without** “electrical isolation”:

Both outputs of the ZMX<sup>+</sup> are opto-decoupled open collector outputs.

**Remark:** In case of inductive loads (e. g. relay, motor brake) protective diodes should be installed!

### 8.2.1 BASIC POSITION

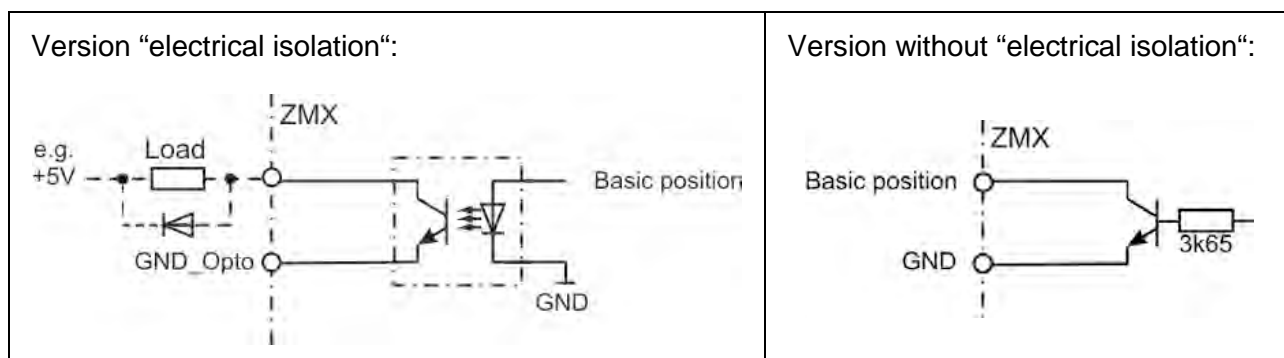

Fig. 24: Output wiring "BASIC POSITION" without electrical isolation

The signals are generated when the internal ring counter passes through zero, after the unit is powered and after a reset

Every ...is generated	for the step resolution
4th control pulse	Full step
8th control pulse	Half step
10th control pulse	1/2.5 step
16th control pulse	1/4 step
20th control pulse	1/5 step
32th control pulse	1/8 step
40th control pulse	1/10 step
80th control pulse	1/20 step

The Basic position signal can be used in combination with an end of run limit switch to determine the machine's zero.

## 8.2.2 ERROR



Abb. 1: Output wiring diagram

This output opens in case of the error messages: under voltage, over current/short circuit and over temperature. The drive is deactivated to avoid error elimination or cooling.

An error message can be reset after damages. The power stage can be reset by the input RESET or in ServiceBus mode.

## 9 ESD Protective Measures

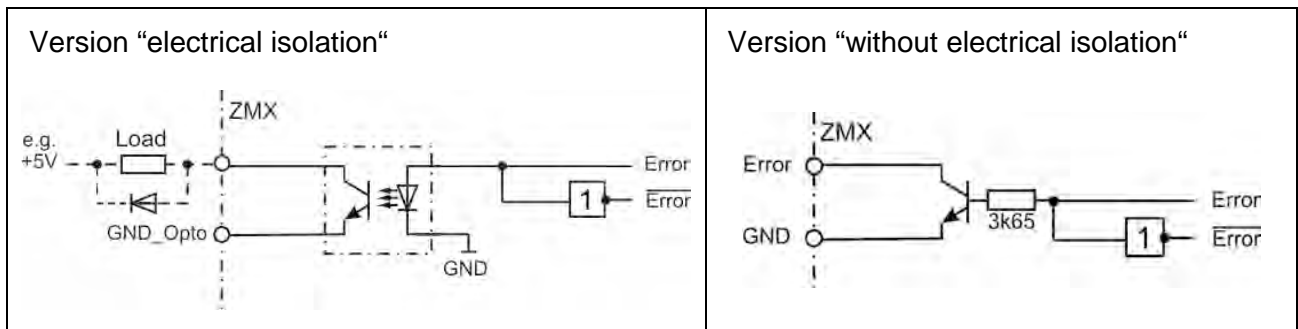
---

Each product is tested before delivery and submitted to an endurance test run. To eliminate failures due to electrostatic destruction (ESD), a great many protective measures have been implemented throughout the entire manufacturing process - from incoming material to outgoing products.



When handling components, ESD protection measures (e. g. EN 61340-5) must be applied. All products returned to our plant must be packaged according to ESD protection specifications.

**Our warranty does not cover failures due to incorrect handling or return packaging which does not conform to ESD specifications.**



## 10 Warranty and Trade Marks

### 10.1 Warranty

---

The ZMX<sup>+</sup> power stages are subject to **legal warranty**. phytron will repair or exchange devices which show a failure due to defects in material or caused by the production process. This warranty does not include damages which are caused by the customer, as there are, for example, not intended use, unauthorized modifications, incorrect handling or wiring.

### 10.2 Trade Marks

---

In this manual several trade marks are used which are no longer explicitly marked as trade marks within the text. The lack of these signs may not be used to draw the conclusion that these products are free of rights of third parties. Some product names used herein are for instance.

- ServiceBus-Comm is a trade mark of Phytron GmbH.
- Microsoft is a registered trade mark and WINDOWS is a trade mark of the Microsoft Corporation in the USA and other countries.

## 11 Technical Glossary

### 11.1 Boost

The motor torque required during acceleration and deceleration is higher than that required during continuous motor operation ( $f_{max}$ ). For fast acceleration and deceleration settings, (steep ramps), the motor current is too high during continuous operation and results in motor overheating. However, a lower phase current results in longer acceleration and deceleration ramps.

Therefore, different phase currents should be used:

- Continuous operation: run current
- During acceleration and deceleration: Boost current

The Boost signal is activated by the superior controller. While input BOOST is energized, a 30 % higher current is flowing.

In the ServiceBus mode the boost value is programmable from 0 to 6.3  $A_{r.m.s.}$

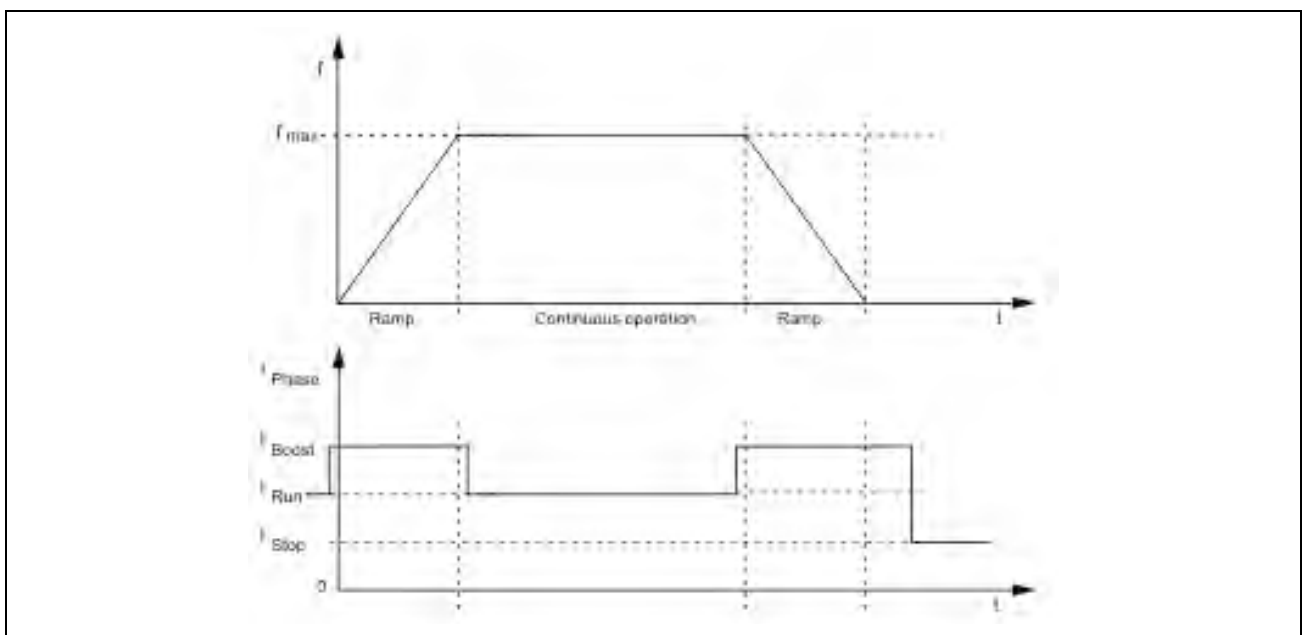

Fig. 25: Boost

## 11.2 Current Delay Time

After the last control pulse the stop current is activated after a time. The time after the last control pulse until the changing to the stop current is called current delay time.

We recommend to specify  $t_{\text{Delay}}$  so that the motor's oscillations are decaying after the last motor step and mispositioning is avoided.

In Rotary switch mode the current delay time is set to 40 ms.

In ServiceBus mode the delay time can be programmed from 1 to 1000 ms in 15 steps.

### Automatic change from run to stop current:

The ratio between both phase currents remains equal in the respective current feed pattern. Changing from run to stop current is achieved synchronously.

In the following figure the next motor step follows after every **rising** control pulse edge:

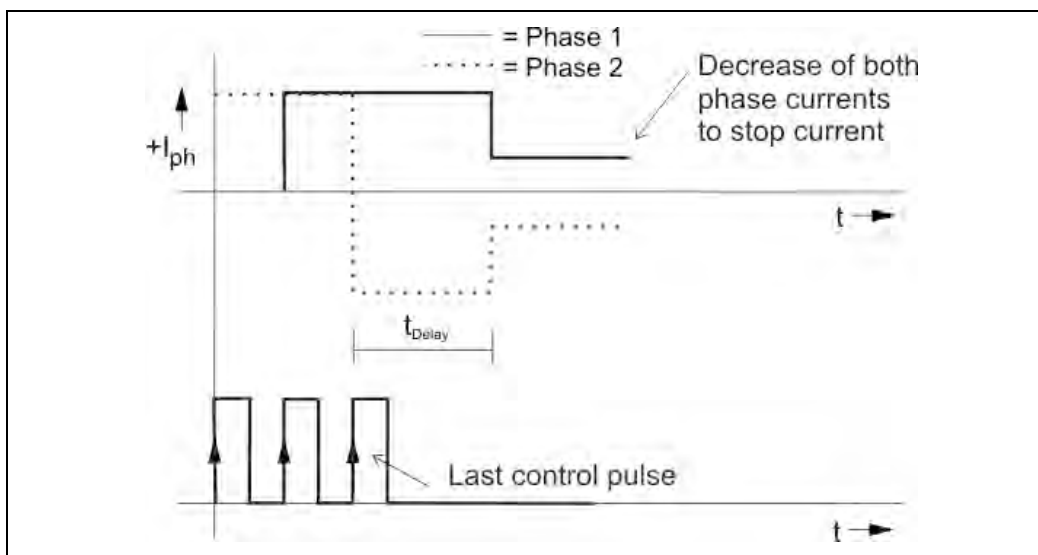

Fig. 26: Decrease to stop current after the last control pulse (full step)

Decreasing to stop current has the following advantages:

- Motor and power stage heating is reduced.
- EMC is improved because of smaller current values.

### 11.3 Overdrive

Power stages can compensate the phase current decrease in the upper speed range by the Overdrive function which is independent of the motor type.

Overdrive is a dynamic boost function, which will be automatically switched on.

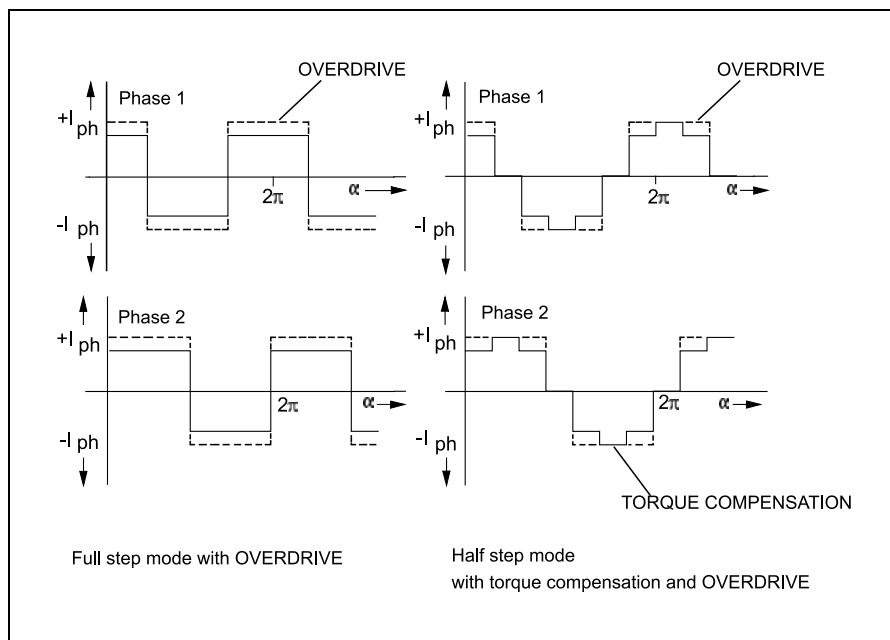

With increasing step frequency the stepper motor phase current decreases, caused by the counter electromotive force of the motor. The amplitude of the current shape is smaller and the motor loses torque.

The Overdrive function works against the reducing of the torque by increasing the r.m.s. phase current automatically by a factor of  $\sqrt{2}$  (generating a rectangle function). It compensates the decrease of the torque. If the speed decreases, the Overdrive is automatically switched off.

The input entire pulse, with which the Overdrive function is switched on or off depends on the step resolution:

Step resolution	Input control pulse frequency	
	Overdrive <b>on</b> at > [kHz]	Overdrive <b>off</b> at < [kHz]
1/1	1.8 kHz	1.6 kHz
1/2	3.6 kHz	3.2 kHz
1/4	7.2 kHz	6.5 kHz
1/5	9 kHz	8.1 kHz
1/10	18 kHz	16.2 kHz
1/20	36 kHz	32.4 kHz

The Overdrive function is activated by a jumper, a switch or the ServiceBus.

## 12 Index

---

### A

Ambient temperature 12

### B

Basic position 44

BASIC POSITION 26, 47

Boost 51

BOOST 25, 43

### C

Calculation 21

CAN 5, 37, 38

CONTROL PULSES 25

Control pulses frequency 42

Copyright 2

Current delay time 42, 52

### D

DEACTIVATION 25, 43

Delivery 6

DIRECTION 25, 45

### E

ERROR 26

### H

Handling 11

### I

Inductivity 28

Inputs 25

Installation 10

Isolation 19

### L

Load capacitor 21

### M

Motor connection 28

Motor time constant 29

### O

Operating mode 7

Outputs 26, 47

Overdrive 53

### P

PELV 13

Phase currents 24

Preferential direction 34, 36, 45

Programming 5

Protective measure 13

Putting into Service 39

### R

Rectifier 21

RESET 25, 44

Resistance 28

Ring counter 44

Rotary switch 24, 34, 36

RS 485 37

### S

ServiceBus 5, 7

ServiceBus connector 26, 31

ServiceBus mode 24

Start/Stop frequency 42

Step resolution 24, 34, 36

STEP RESOLUTION 25, 46

Stepper motor 24, 28

Supply Unit 22

Supply voltage 24

### T

Touch voltage 14

Trade marks 50

Transformer 21

Type 23, 31, 32

### W

Warranty 50

Weight 23

Winding inductance 28

Winding resistance 28

Wiring scheme 28

**Phytron GmbH • Industriestraße 12 • 82194 Gröbenzell, Germany**  
**Tel. +49(0)8142/503-0 • Fax +49(0)8142/503-190 • E-Mail [info@phytron.de](mailto:info@phytron.de) • [www.phytron.de](http://www.phytron.de)**

**Phytron, Inc. • 600 Blair Park Road Suite 220 • Williston, VT 05495 USA**  
**Tel. +1-802-872-1600 • Fax +1-802-872-0311 • Email [info@phytron.com](mailto:info@phytron.com) • [www.phytron.com](http://www.phytron.com)**